

Software Correlation for VLBI

Mark Kettenis, JIVE



Collaborators

- JIVE

- Aard Keimpema
- Yurii Pydoprihora
- Des Small



- University of Amsterdam

- Damien Marchal



UNIVERSITY OF AMSTERDAM

- PSNC

- Marcin Okan
- Dominik Stoklosa



Netherlands Organisation for Scientific Research

Correlation

XF:
$$\int_0^T \int_0^T f(\tau) g(t-\tau) d\tau e^{i\nu t} dt = \int_0^T f(t) * g(t) e^{i\nu t} dt$$

- Large number of simple operations
- Easy to implement in hardware

FX:
$$F(\nu) \cdot G(\nu) = \int_0^T f(t) e^{i\nu t} dt \cdot \int_0^T g(t) e^{i\nu t} dt$$

- Small number of complex operations
- Easy to implement in software
- Better accuracy with floating-point

Algorithm

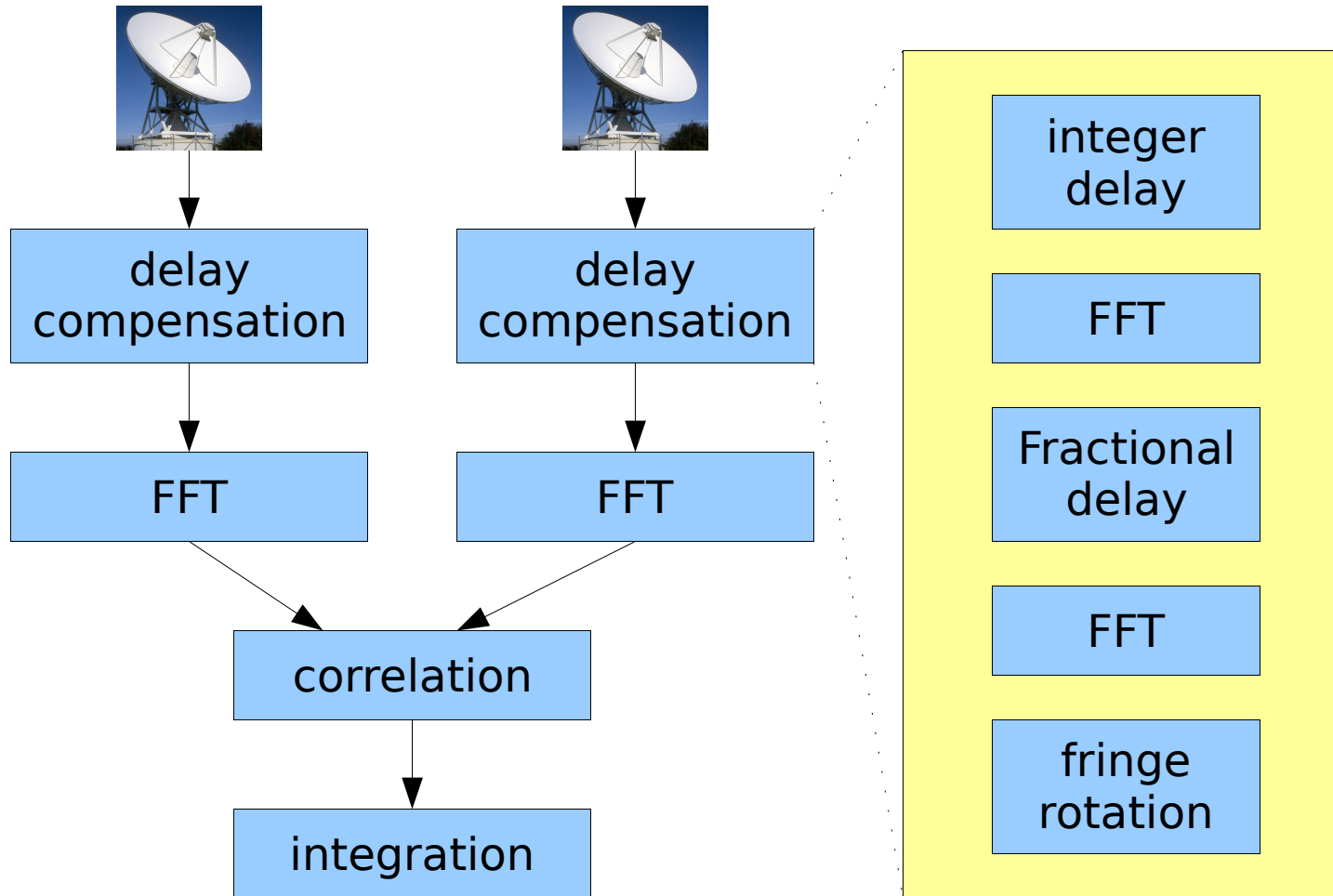

Complexity

- Per station processing

1. FFT from time domain to frequency domain
real-to-complex: $5 \log N_f$ flops/sample

2. fractional bit shift
complex multiplication 6 flops/sample

3. FFT from frequency domain to time domain
complex-to-real: $5 \log N_f$ flops/sample

4. fringe stopping
complex multiplication 6 flops/sample

5. FFT from time domain to frequency domain
real-to-complex $5 \log N_f$ flops/sample

- Per-baseline processing

1. correlation
complex multiplication 6 flops/frequency point

2. integration
addition/division 2 flops/frequency point

FLOPS

- Current JIVE correlator:
16 stations, 8 bands, 4 pols,
32 spectral pts, 1 Gb/s

1.8 TFlops

- EVLA correlator:
27 stations,
4 bands, 4 pols,
128 spectral pts,
32 Gb/s

244 TFlops

So a top 10 supercomputer can do this!

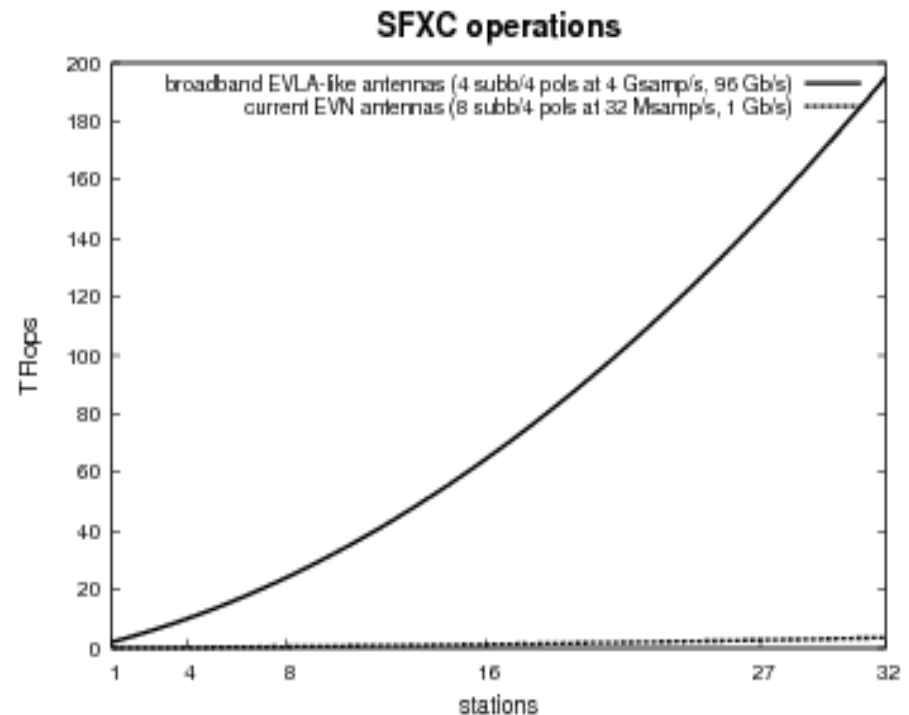

Parallelization

- Easy
 - Subbands
 - Polarizations
 - Time (per integration)
- Somewhat more complex:
 - Time (per “chunk”)
- Pointless?
 - Baselines
 - Per-telescope processing dominates
 - 2-bit samples -> float: 16-fold increase

Topology

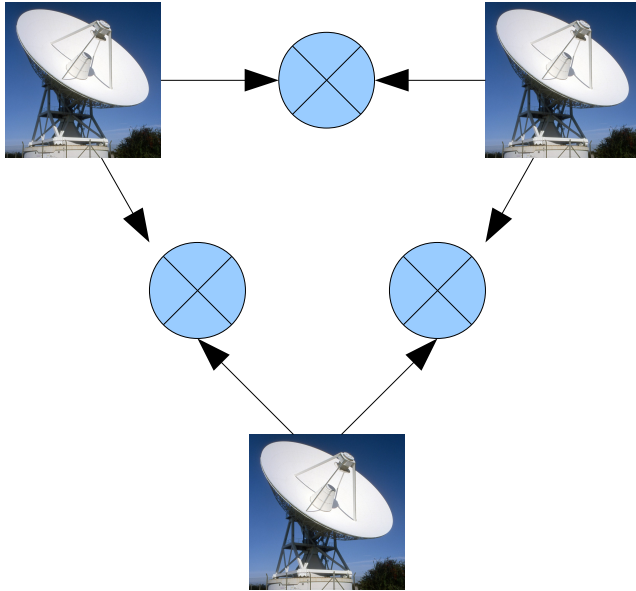

Problems:

- Data duplication
- Duplication of per-telescope processing

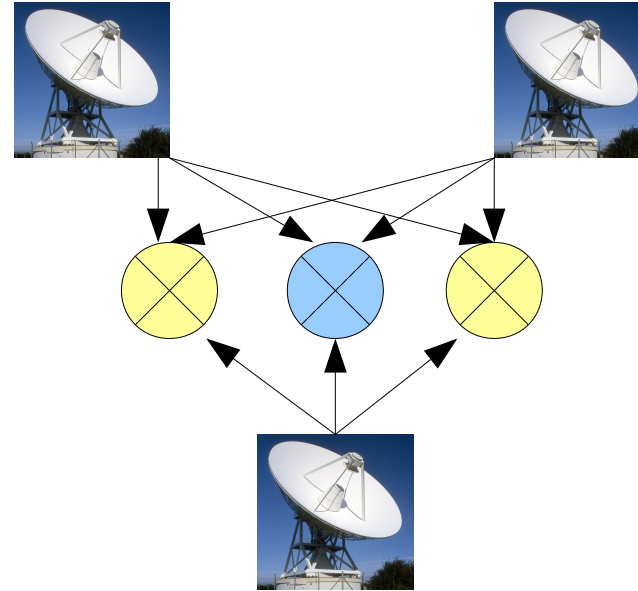

Problems:

- Scalability

Implementation

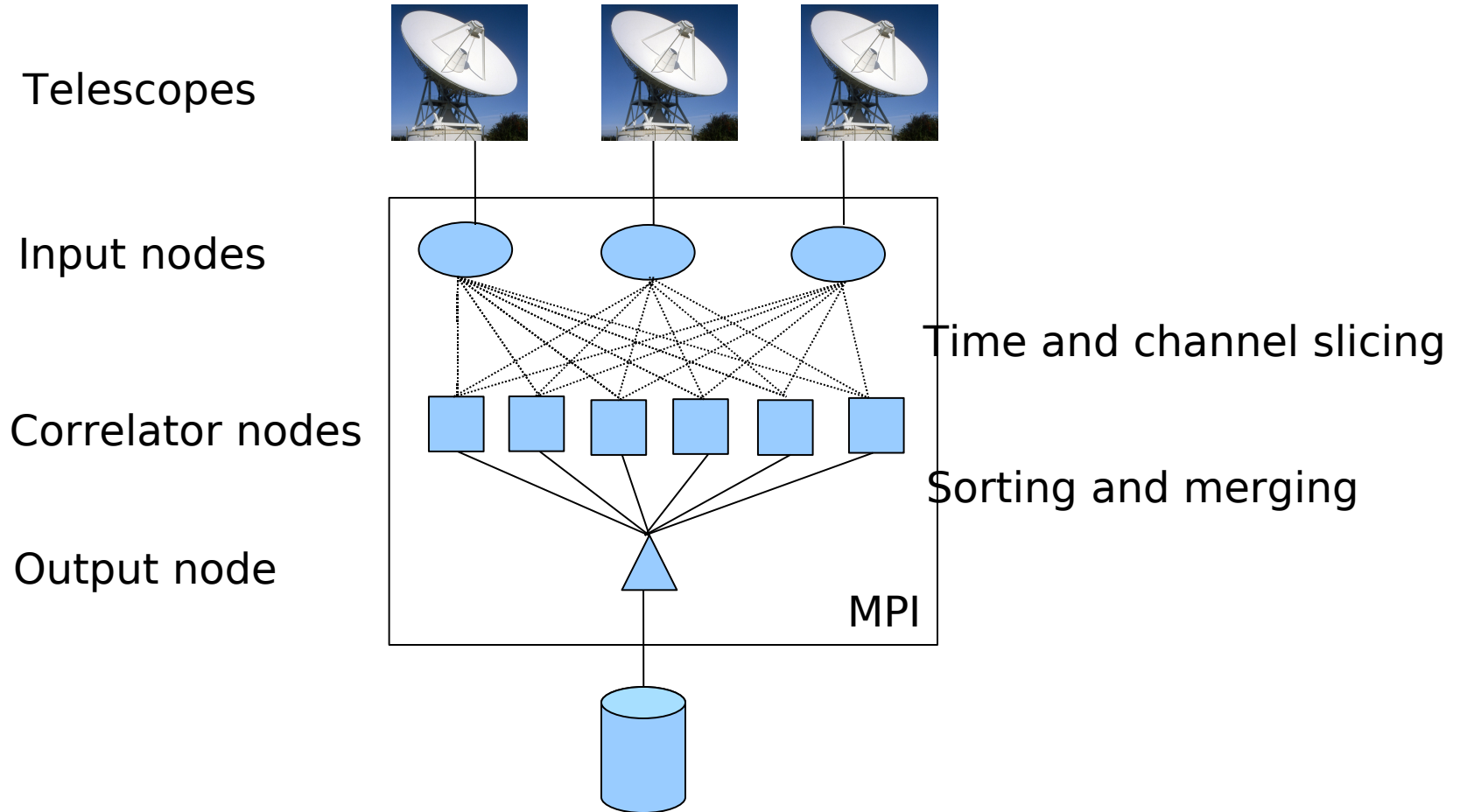

Validation

- Comparison with hardware correlator

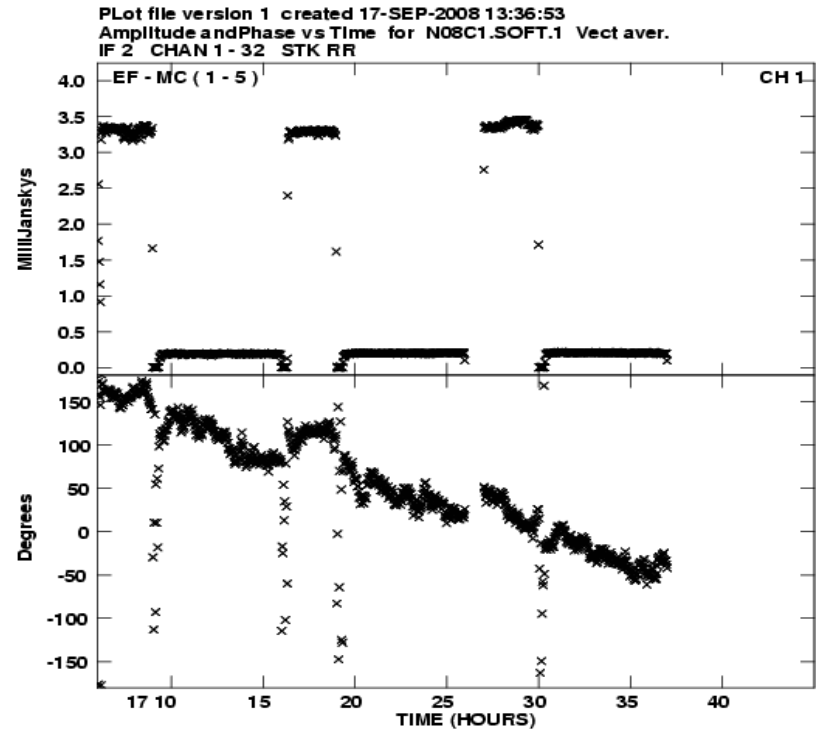
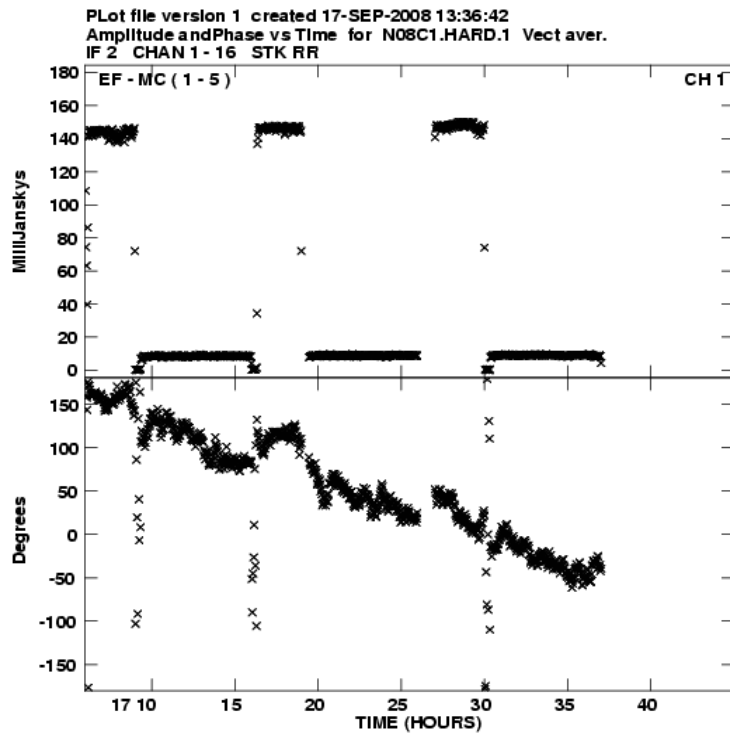

Validation

- Allan standard variation

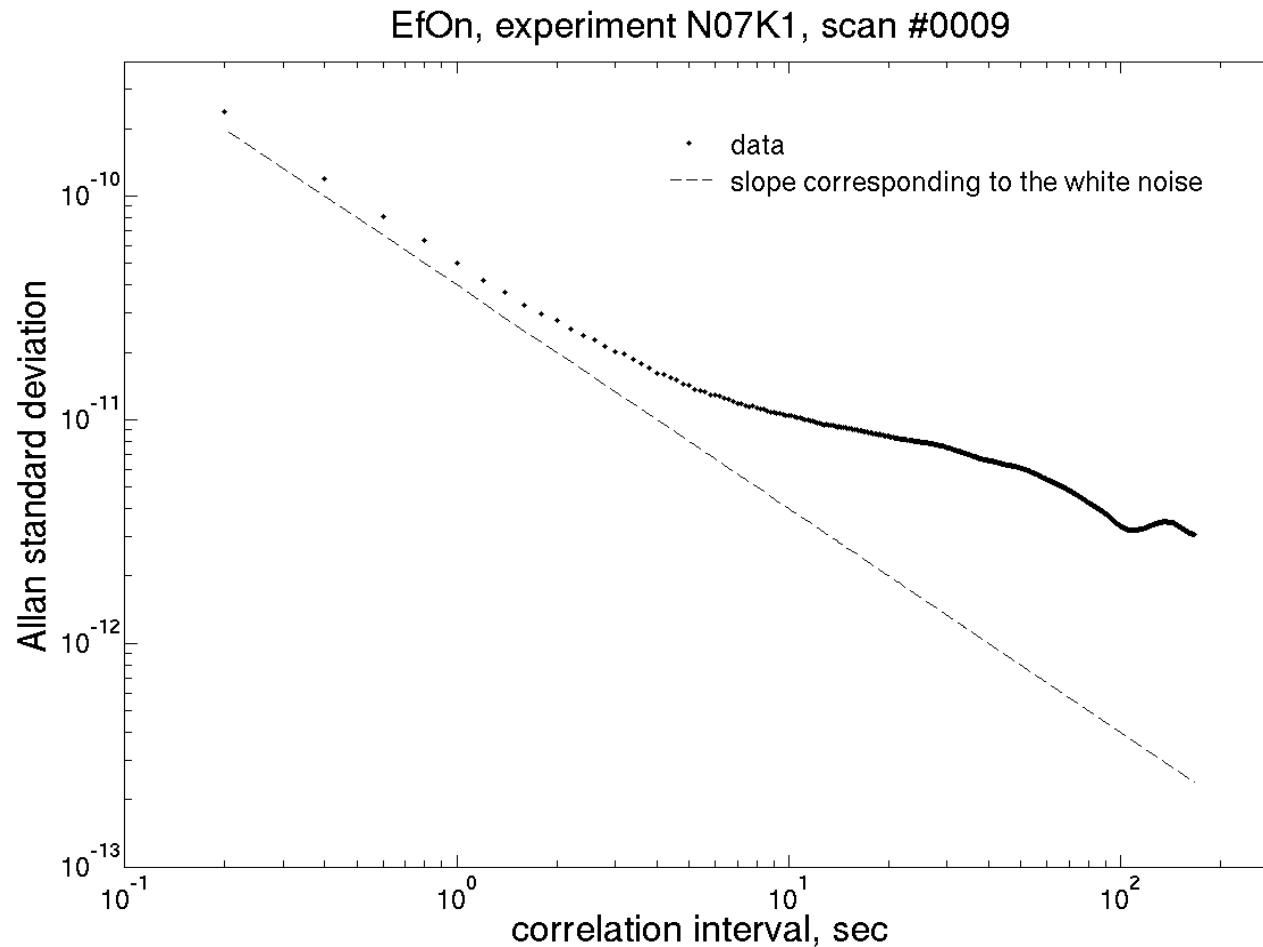

FTP Fringe Tests

- Important feedback for telescopes

[Show plots](#)

	Auto correlation				Cross correlation					
	Ef	Nt	Mc	On	Ef-Nt	Ef-Mc	Ef-On	Nt-Mc	Nt-On	Mc-On
CH01, 2203.99 MHz, USB, Rcp	A	A	A	A	34.02	45.62	17.38	20.74	10.95	12.62
CH02, 2219.99 MHz, USB, Rcp	A	A	A	A	30.6	53.39	13.23	26.08	13.67	12.88
CH03, 2243.99 MHz, USB, Rcp	A	A	A	A	29.94	19.99	16.44	13.75	10.98	4.723
CH04, 2283.99 MHz, USB, Rcp	A	A	A	A	25.51	53.06	14.29	23.27	12.13	9.903
CH05, 2299.99 MHz, USB, Rcp	A	A	A	A	35.51	4.39	13.7	2.677	13.71	3.064
CH06, 2331.99 MHz, USB, Rcp	A	A	A	A	2.304	41.2	11.97	2.685	2.646	12.37
CH07, 8211.99 MHz, LSB, Rcp	A	A	A	A	86.87	144.1	37.35	26.65	5.897	10.25
CH08, 8211.99 MHz, USB, Rcp	A	A	A	A	112.5	208.6	46.89	33.62	6.784	12.25
CH09, 8227.99 MHz, USB, Rcp	A	A	A	A	105.7	209.4	41.66	33.51	5.963	12.1
CH10, 8251.99 MHz, USB, Rcp	A	A	A	A	2.694	4.214	2.609	31.76	5.27	12.23
CH11, 8315.99 MHz, USB, Rcp	A	A	A	A	85.97	201	38.35	32.83	8.808	14.01
CH12, 8427.99 MHz, USB, Rcp	A	A	A	A	103.9	192	42.19	38.02	7.186	10.66
CH13, 8499.99 MHz, USB, Rcp	A	A	A	A	92.58	199.3	42.48	37.24	6.661	13.43
CH14, 8539.99 MHz, USB, Rcp	A	A	A	A	80.98	201.6	44.96	28.93	8.184	14.69
CH15, 8579.99 MHz, LSB, Rcp	A	A	A	A	33.49	141.8	35.61	8.895	3.097	12.05
CH16, 8579.99 MHz, USB, Rcp	A	A	A	A	11.14	182.4	42.42	3.811	3.607	14.92

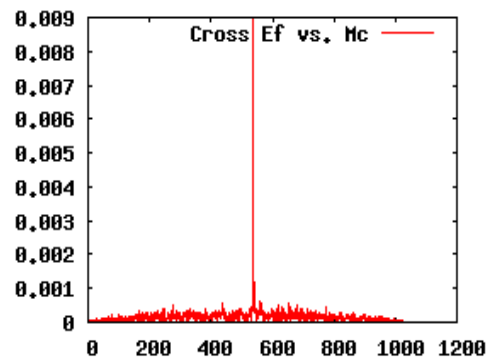

Webservices

How to get things on the Grid?

- vex2ccf: Creates control file template based on VEX file.
- Translation node: Provides chunks of data for a single telescope and transfers them to GridFTP servers.

Implemented in Python using ZSI framework

- SOAP 1.1
- HTTP 1.0 (with some 1.1 elements)

Webservices (2)

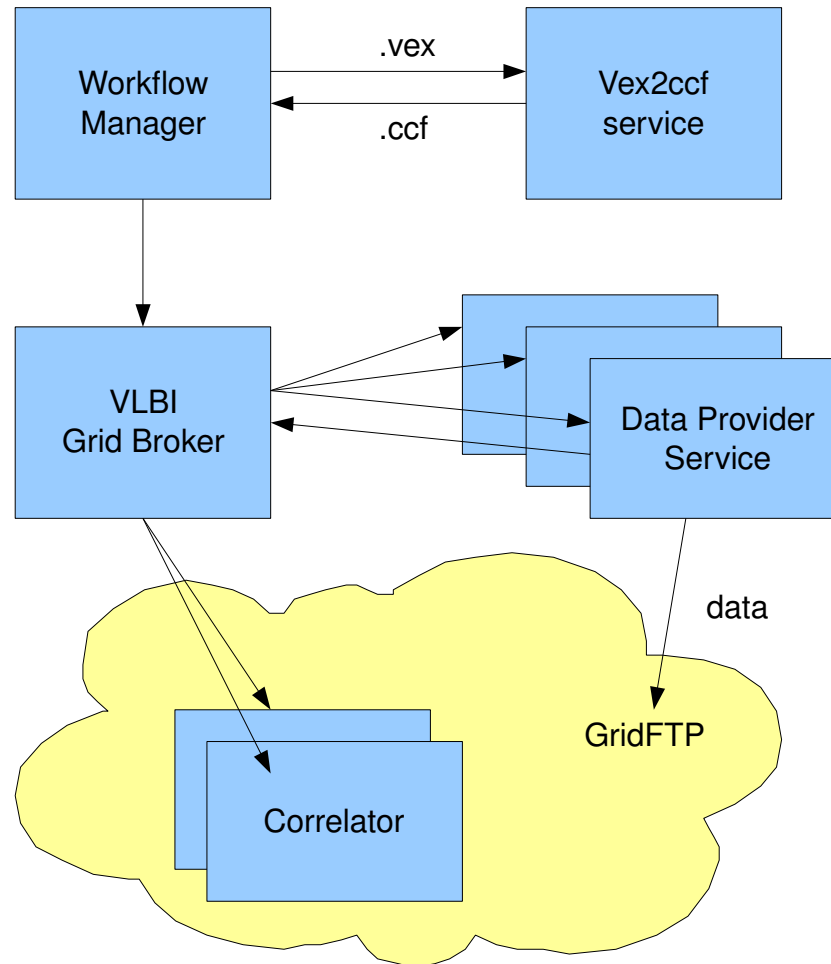

AutoBAHN

- JRA within GEANT2 developing a bandwidth-on-demand facility across domains
- Being deployed by NRENs of Greece, Ireland, Poland and Croatia, using the GEANT2 testbed

- Interfaces to other BoD-systems (DCN, DRAC).
- Making reservations:
 - Web interface
 - Webservice

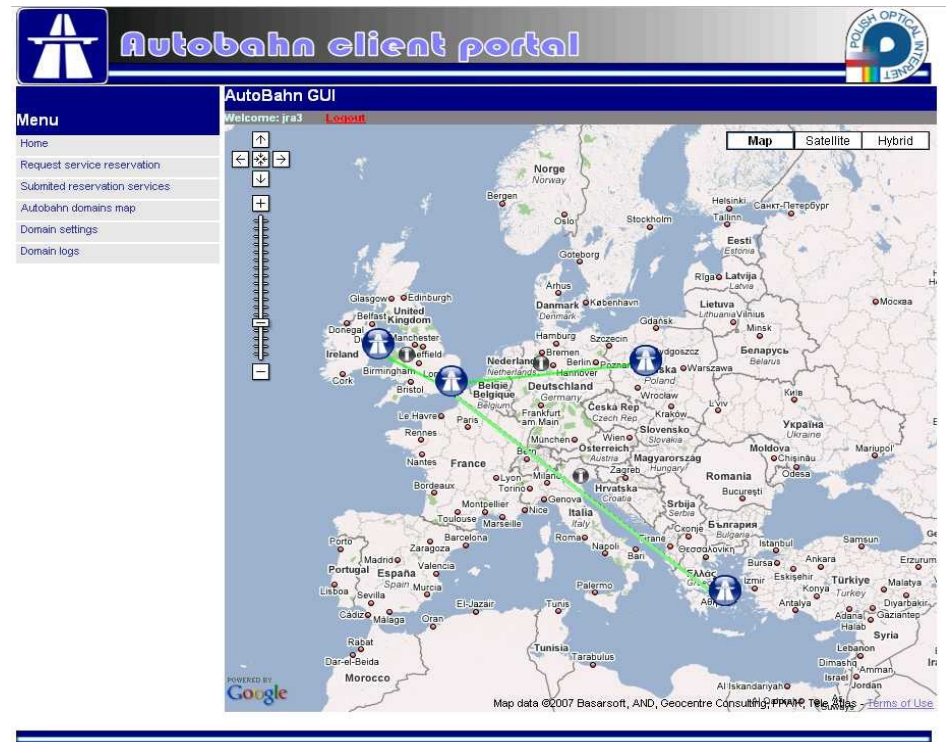

AutoBAHN demo

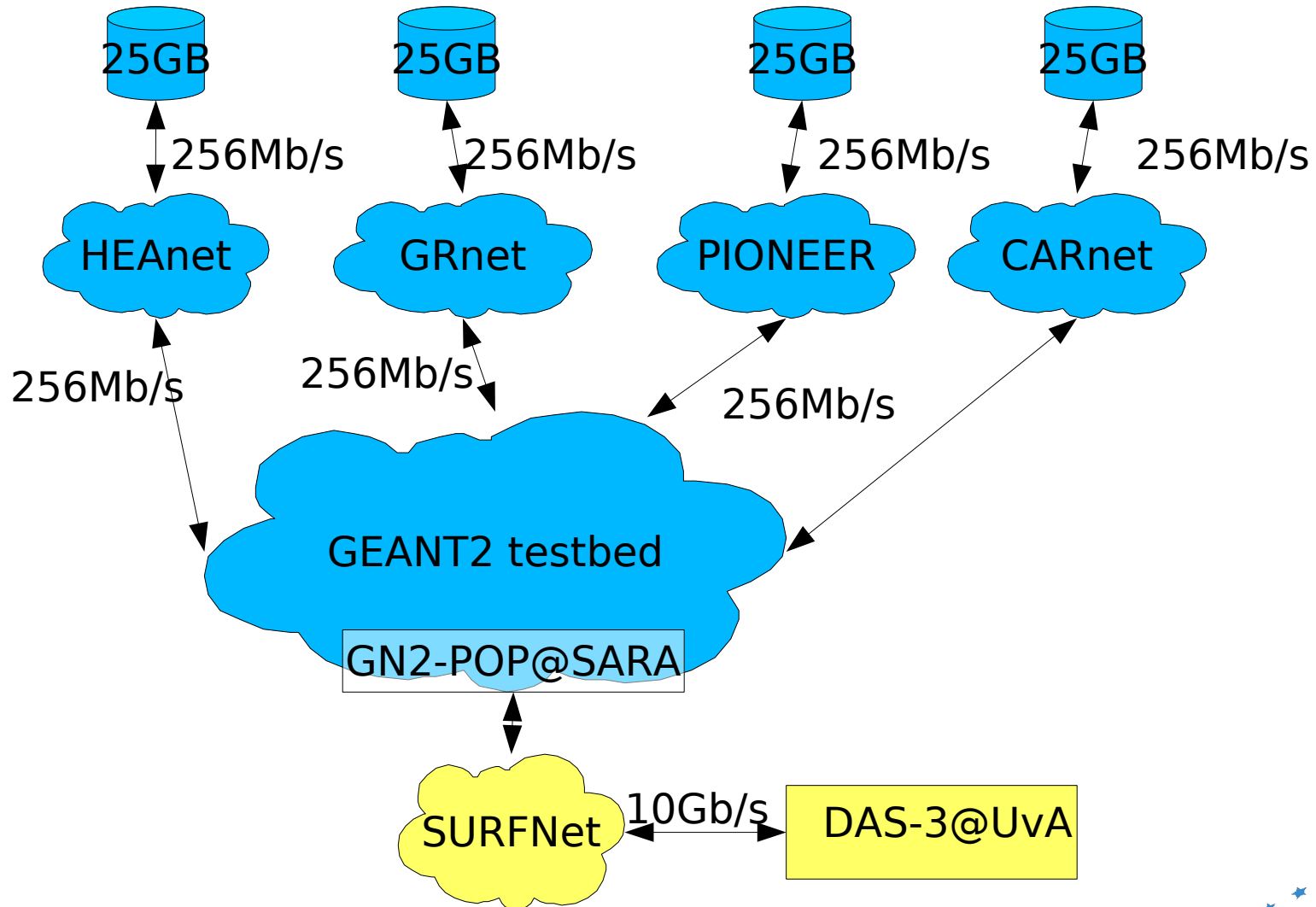

Square Kilometer Array

- Radiotelescope with a collecting area of 1 km²
- Likely to be many small dishes or dipoles
- In a remote part of Australia or South Africa

Possible to correlate in software?

New computing architectures (GPU, Cell)?

New network architectures?